

# *Safe practice*

*for the handling  
of doctor blades.*



**JOH. CLOUTH®**

# Safety equipment

- When handling doctor blades always wear personal safety equipment.

We recommend:

**Cut-resistant gloves,  
safety glasses,  
safety shoes.**

**Attention: Blade changes to made only when machine stopped!**

# System accessories

- Ensure appropriate tools are used when changing blades. We recommend:

## **CLOUTH DOCTOR-PULL®**



## **CLOUTH-POWER-PULL®**



- Dispose of used doctor blades as soon as possible.

An ideal solution is the  
**CLOUTH DOCTOR-CUT®**.



**Attention: Never leave blades unattended on machine floor, near gangways or on stairs!**

**Extremely high risk of injury!**

- Optimal storage conditions are provided by the **CLOUTH DOCTOR-STORE**®.

When using the stores we supply the blade in the **CLOUTH DOCTOR-BOX**®.

The blades are equipped with system holes and connected to each other.

To remove the blades, it is not necessary for them to be unpacked.

The doctor blades are numbered in reverse, showing how many blades are left in each box.



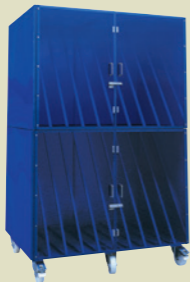

**Attention: When using other packaging, always take great care as the rolled blades are under high tension.**

# Adjusting recommendations and practical tips



***JOH. CLOUTH***<sup>®</sup>

# Basic parameters for good doctoring

1. Parallelism of doctor unit and roll/cylinder surface.
2. The correct angle.
3. The correct pressure.
4. The correct choice of doctor blade material.
5. Correct maintenance of the doctor holders.
6. Regular inspection of doctor bearings.  
(Eccentric adjustment, correct function of pneumatic cylinders and related components)
7. Advice for the start-up of metal blades.

# 1. Parallelism of doctor unit and roll/cylinder surface.

When measuring the angle on the tender side and drive side the difference in angle should be under  $2^{\circ}$ .

For easy and fast measuring we recommend the **CLOUTH<sup>®</sup> - DOCTOR BLADE ADJUSTING GAUGE**.

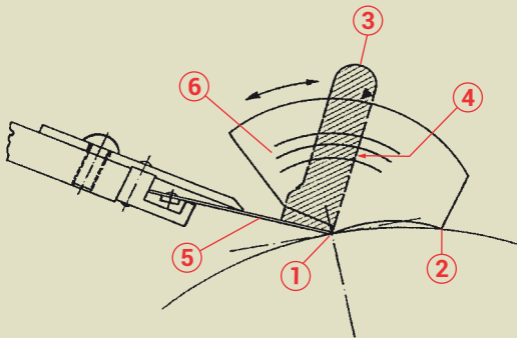



1. Clouth® Doctor Blade Adjusting Gauge with the point (1) at the Doctor blade tip and with point (2) on the roll surface
2. Then, adjust the plastic slot (4) in such a way with lever (3) that this fits snugly on the blade, at measuring point (5). By means of scale (6) and the blue marked edge (4) at the slot you can read off current angle. The angle should be checked in this way at both tender and drive-sides of the machine and in between. If all measurements are the same, the blade is adjusted equally across the roll face.



## PLEASE NOTE

1. Always make measurements with a new doctor blade installed.
2. Please ensure that the blade pocket/holder groove is clean to ensure even blade contact.
3. Before changing the angle of a doctor blade, you are advised to check with your blade supplier.
4. Careful use of the Clouth® Doctor Blade Adjusting Gauge is required to achieve accurate results.

## 2. The correct angle.

## 3. The correct pressure.

Changing of doctor blade loading during operation with run-in blade.

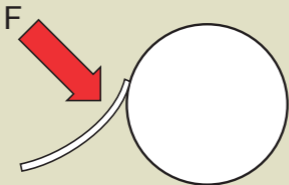

**Attention: Never increase blade pressure during running as this may cause the accumulation of fibres under blade tip, leading to passing. Blade pressure may be reduced when running.**

<b>Position</b>	<b>Blade angle</b>	<b>Blade pressure N/m</b>
Breast roll	20°-25°	100-200
Wire guide roll	20°-25°	100-200
Suction roll	20°-25°	100-200
Unfelted press roll	26°-28°	250-350
Felted press roll	25°-27°	100-250
Felt guide roll	20°-25°	100-200
Drying cylinder	25°-30°	200-350
Cooling cylinder	25°-30°	200-350
MG (Yankee)		
MG (Yankee)	25°-27°	300-400
Soft calender roll	16°-18°	50-150
Steel calender roll	25°-28°	200-250
Pope reel	25°-28°	150-200

## 4. The correct choice of doctor blade material.

The correct choice of doctor blade material can be found on our homepage.

Here are some examples of combinations which should **not** be used.

We are pleased to offer you extensive training and advice.

Chromed surface:

Copper cylinders:

Teflon Coating:

Beltex rolls:

Wire section:

Drying Section:

Felt guide rolls:

Press rolls:

PU rolls:

Granite rolls:

Ceramic rolls:

Soft calender roll:  
soft cover:

Chrome rolls:

- no** MONEL, STEEL, BRONZE, CLOUTH-MG-FF<sup>®</sup>, DIACLOUTH-600<sup>®</sup>
- no** MONEL
- no** MONEL, BRONZE
- no** CLOUTH<sup>®</sup>-RED
- no** CLOUTH-ABRASIV<sup>®</sup>
- no** CLOUTH-KLEEN<sup>®</sup>, CLOUTH-MG-FF<sup>®</sup>, CLOUTH<sup>®</sup>-OG, CLOUTH<sup>®</sup>-RED, CLOUTH-AS<sup>®</sup>, DIACLOUTH-600<sup>®</sup>
- no** CLOUTH<sup>®</sup>-RED
- no** CLOUTH<sup>®</sup>-OG
- no** CLOUTH-KLEEN<sup>®</sup>
- no** stainless steel  
(at higher speeds risk of sparking)
- no** metal  
except Clouth DT 1.4021 on CeraLease (Voith)
- no** synthetic blades,  
except Combifibre<sup>®</sup>-100C
- no** special steel and no phenolic resin blades

## 5. Correct maintenance of the doctor holders.

- Regular maintenance of the pressure tubes; change when damaged or brittle.
- Regular cleaning of blade pocket and holder fingers.
- The **CLOUTH DOCTOR-CLEAN**<sup>®</sup> is ideal for this.
- Regular checking of top-plate.

Replace damaged steel top-plates with **CLOUTH-CONTOUR**<sup>®</sup> carbon fibre material.



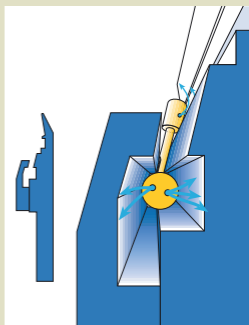

## 6. Regular inspection of doctor bearings.

When experiencing doctoring problems always check the doctor bearings and the mountings of the beam for parallelism and function (turnbuckles/pneumatic cylinder).

**Attention: Never adjust the doctoring system when the bearing is defective, as the forces created will change the geometry of the system.**



# Adjustment mistakes when mounting doctor beams.

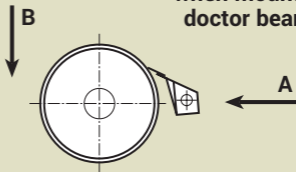

**View A**

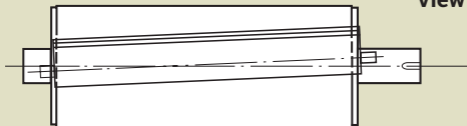

**View B**

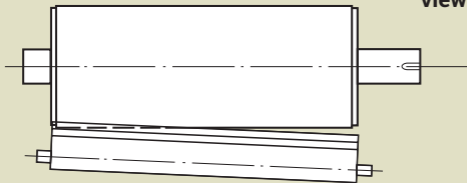

## 7. Advice for the start-up of metal blades.

When using metal blades on stone replacement rolls your **must** always adhere to the following procedure.

- Before start-up, lift off doctor blade.
- Moisten roll sufficiently (where showers installed).
- Never load the doctor blade during “crawl”.
- Start roll.
- Load the blade only when a speed of **100 m/min (300 ft/min)**.

- This procedure must be repeated every time the roll is stopped and re-started.
- Always lift off the blade whenever the roll is stopped, otherwise the blade may dig into the roll.

**This advice is for all metal blades, whether from bronze, monel, steel, stainless steel or DT stainless steel.**

**Attention:**

- **Roll surface must have an even form.**
- **The blade pressure must be evenly distributed.**
- **The bearings must be in good condition.**



**This advice is intended as a guide only and is given without prejudice. It is the responsibility of the user to ensure the suitability of products and conditions of use.**

**The use of our products is outside of our control and it is therefore the responsibility of each user to ensure suitability for each application.**

Extensice help and  
product descriptions  
are available at

**[www.clouth.com](http://www.clouth.com)**

For personal advice contact us at:

**E-Mail: [info@clouth.com](mailto:info@clouth.com)**

**or**

**Telefon: +49 2192 853 0**

Joh. Clouth GmbH & Co. KG  
Johann-Clouth-Str. 1-5  
D-42499 Hückeswagen

# Notes







***JOH. CLOUTH®***